

Umbrella

Origin



- The umbrella (parasol) was invented about 4,000 years ago in Ancient Egypt. These ancient umbrellas were first designed to provide shade from the sun
- Around 11th century BC, China waterproofed the umbrellas by using silk and oil paper
- In the early 16th century, the umbrella became popular in the western world
- In 1852, Samuel Fox invented the steel ribbed umbrella design
- In 1928, Hans Haupt invented the pocket umbrella, nicknamed the “Flirt.”



Repel Windproof Travel
\$23



Rain-Mate
\$21



Amazon Basics
\$18



Devek
\$49



Herschel
\$40



Supreme
\$54



Alexander McQueen
\$625



Burberry
\$290



Louis Vuitton
\$1194

Form & Function

Symmetrical from all angles (top, bottom, side)







Octagonal (8-sided canopy, 8 stretchers, 8 ribs)

8-sided canopy

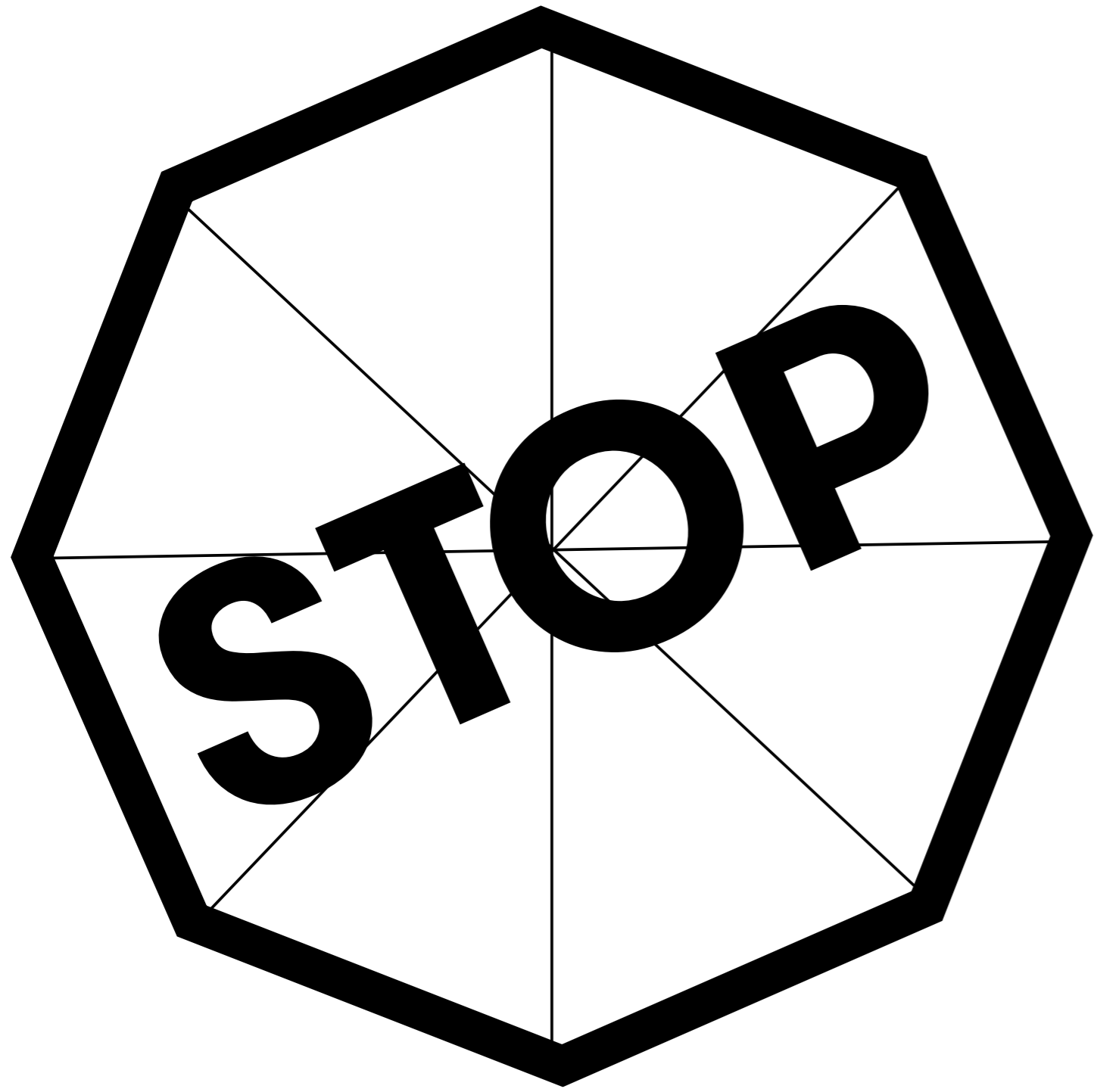

Panel of canopy



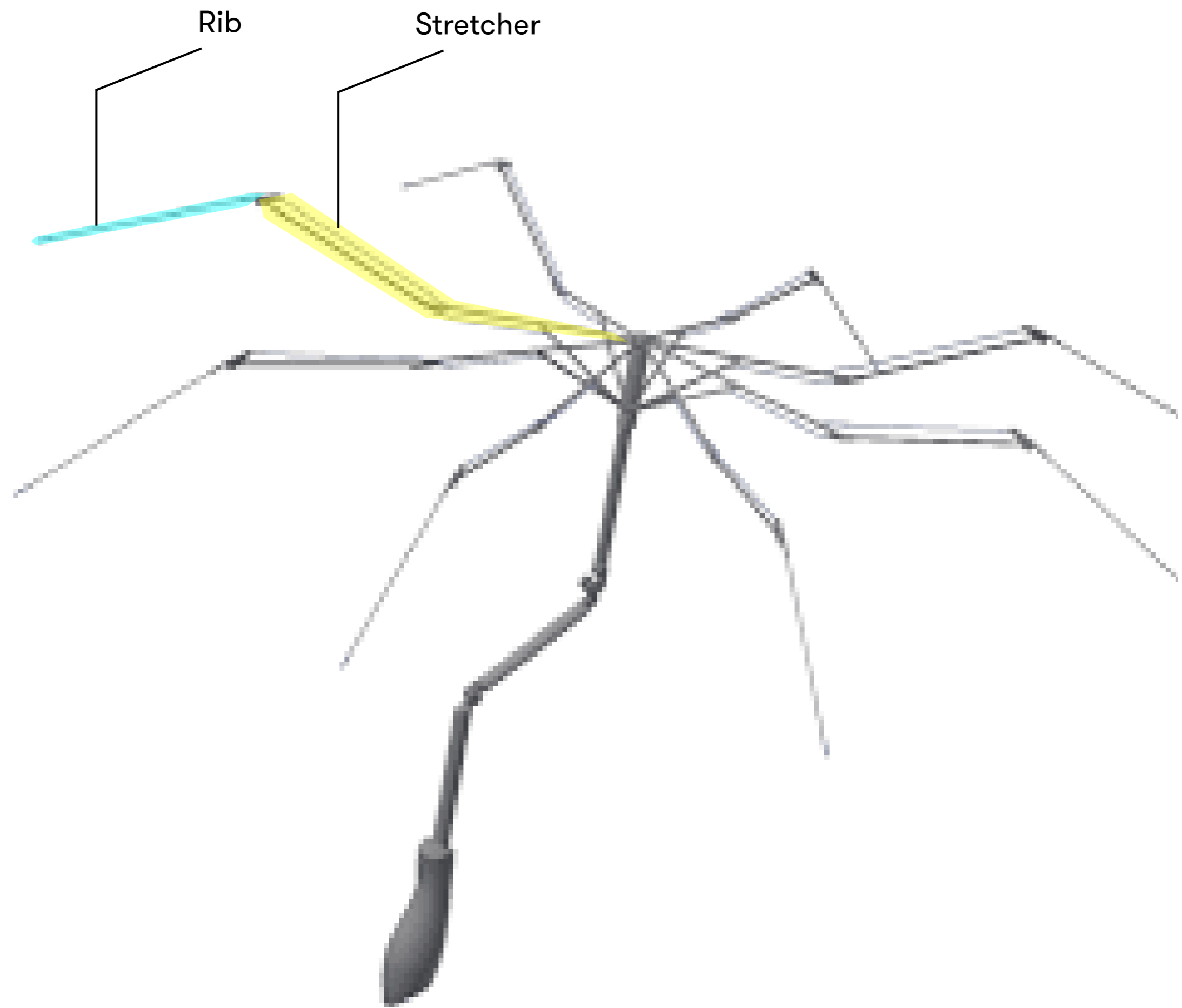

Waterproof material

Nylon taffeta or a nylon & woven fabric blend.
Acrylic coating on bottom and Scotch Guard on top.



Mechanism and detailed description of the embodiment

An automatic umbrella control mechanism is generally comprised of 6 main parts:

hollow handle 10

socket 20

receptacle 30

tube 40

umbrella shaft 50

button 60.

Hollow handle **10**

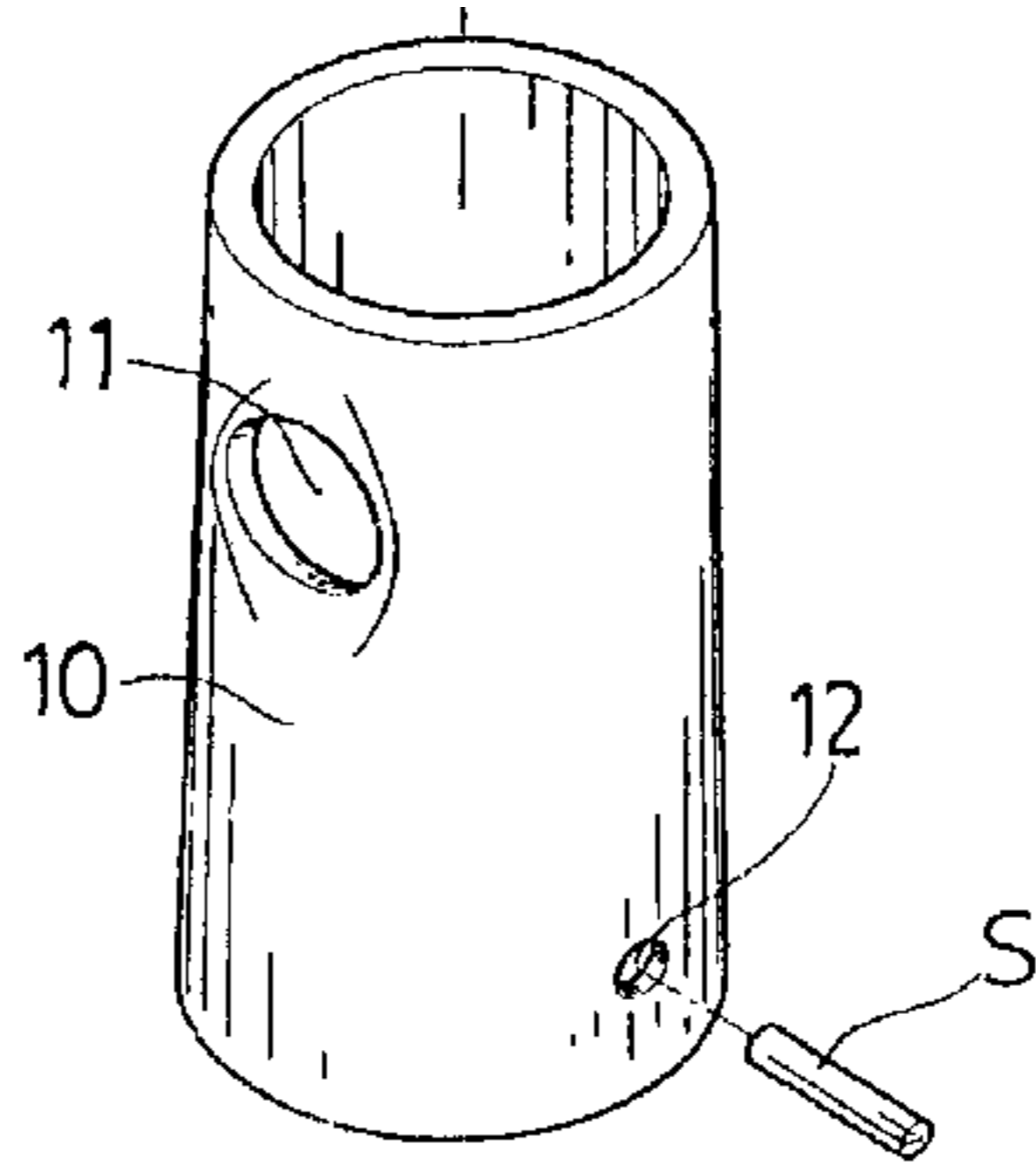

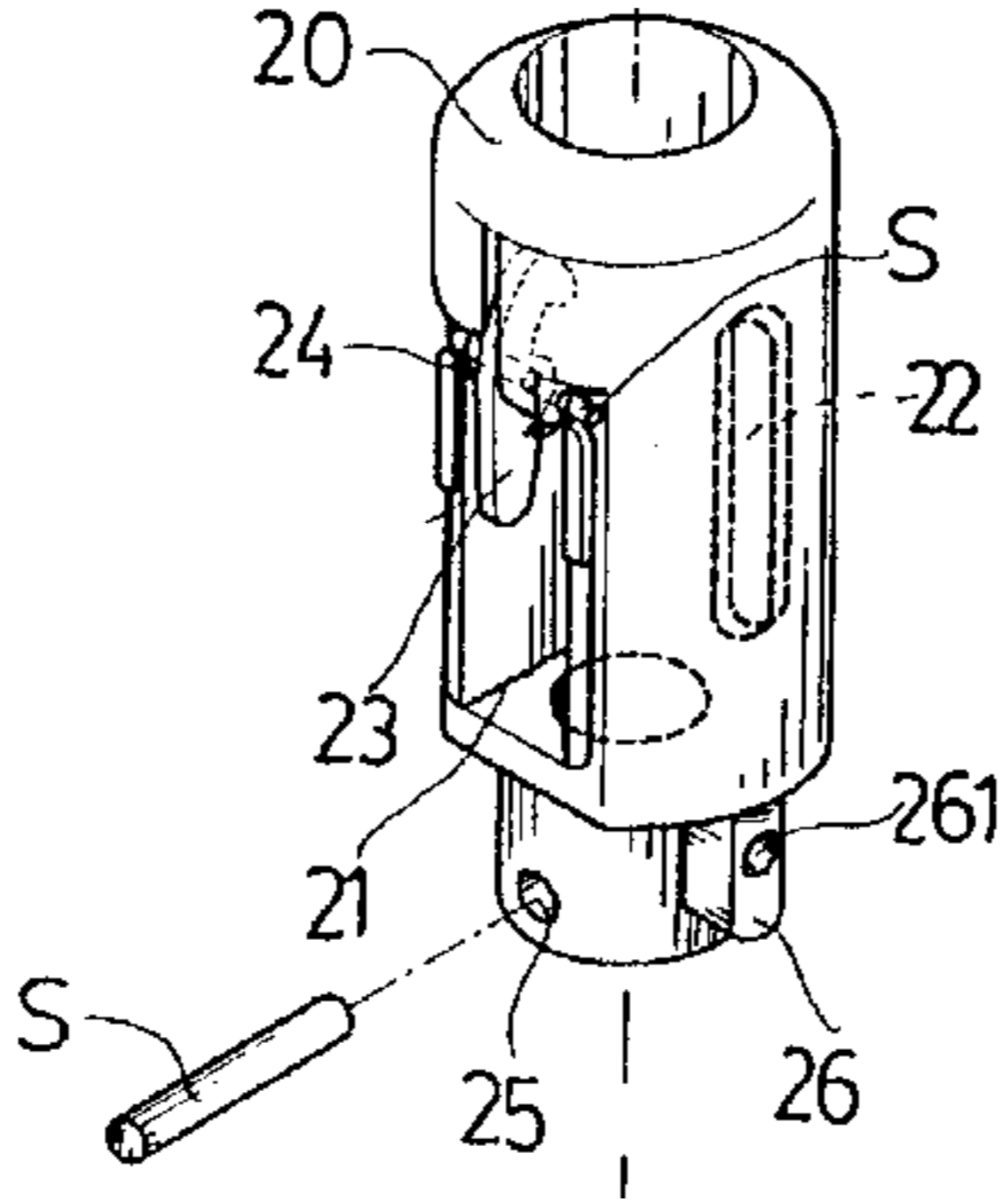

Receptacle 30

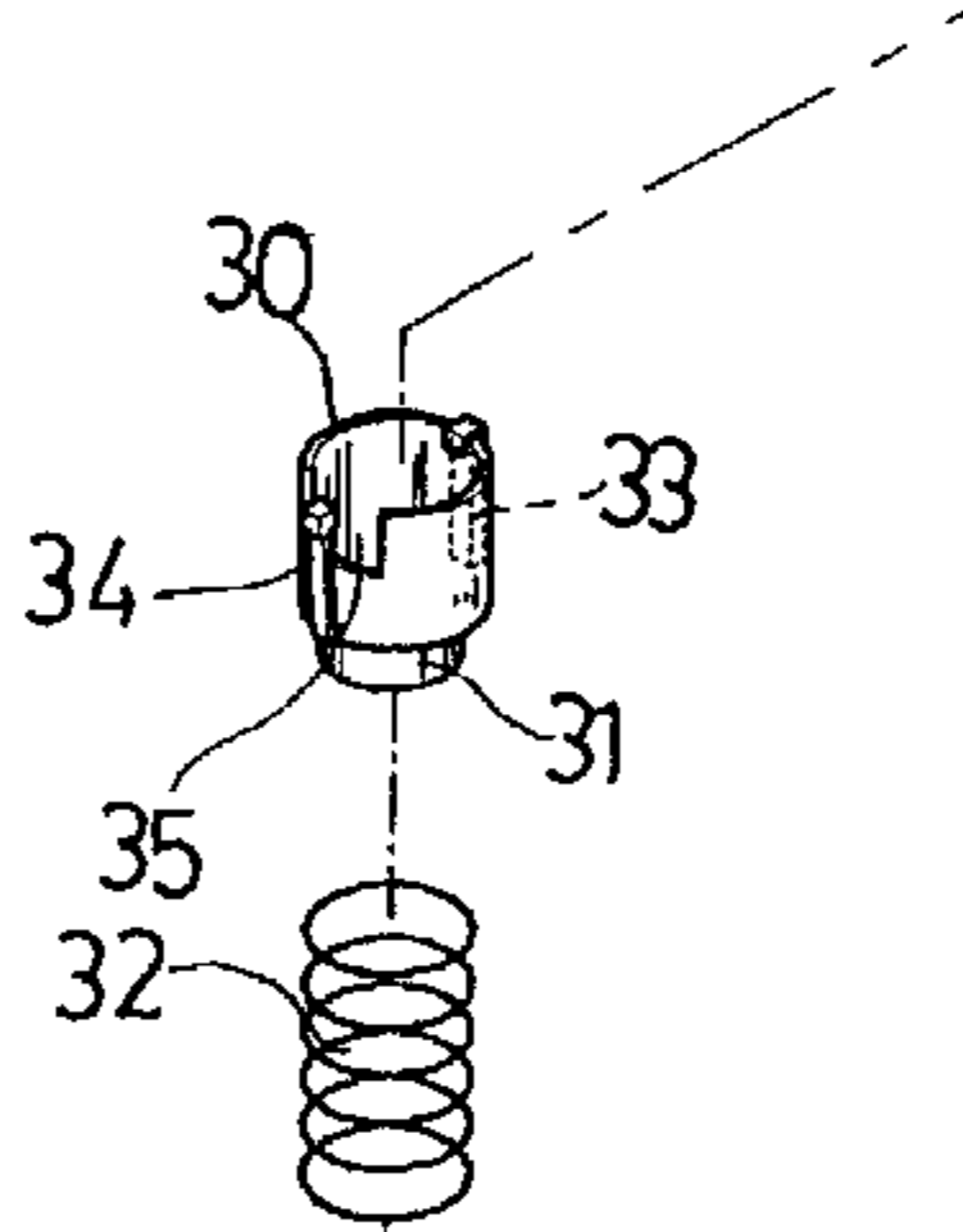

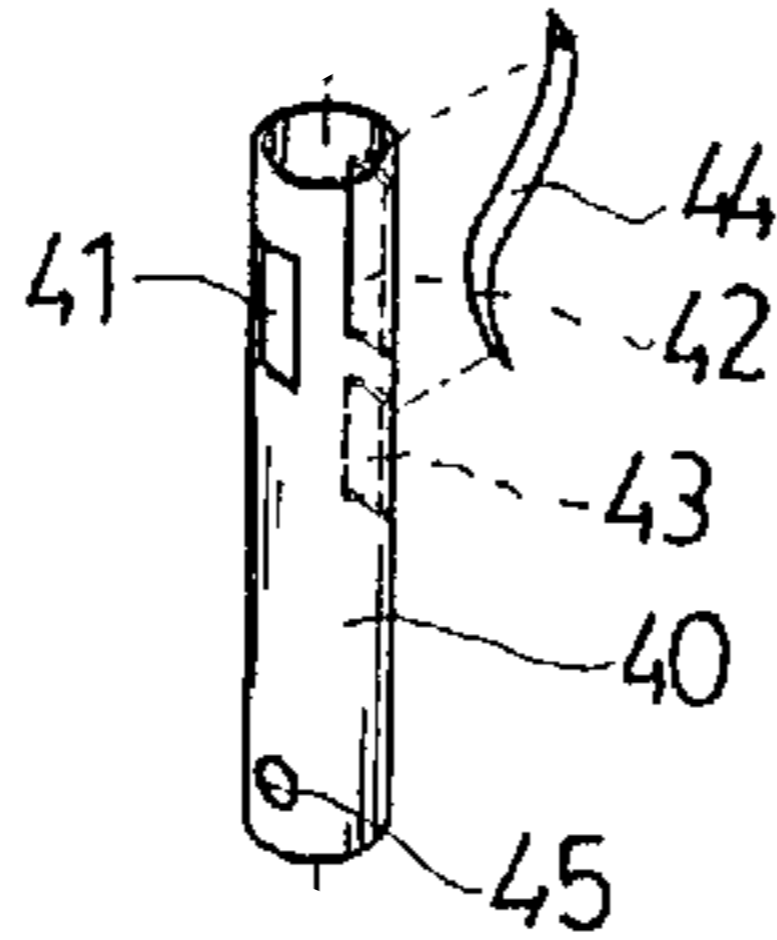

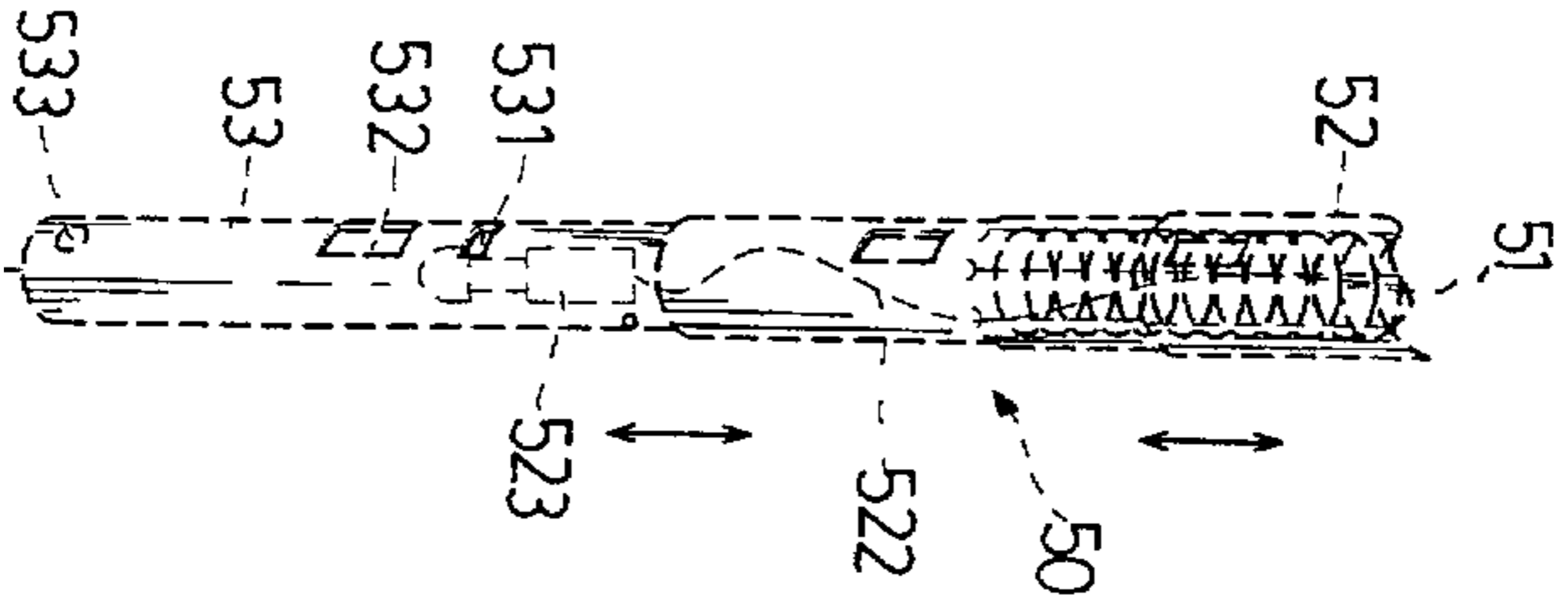

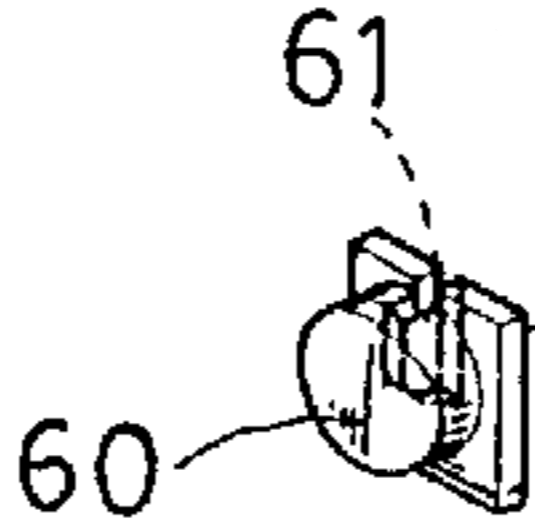

Hollow handle 10

The handle **10** comprises a round hole **11** through the peripheral wall near the top, and a pinhole **12** through the peripheral wall near the bottom.

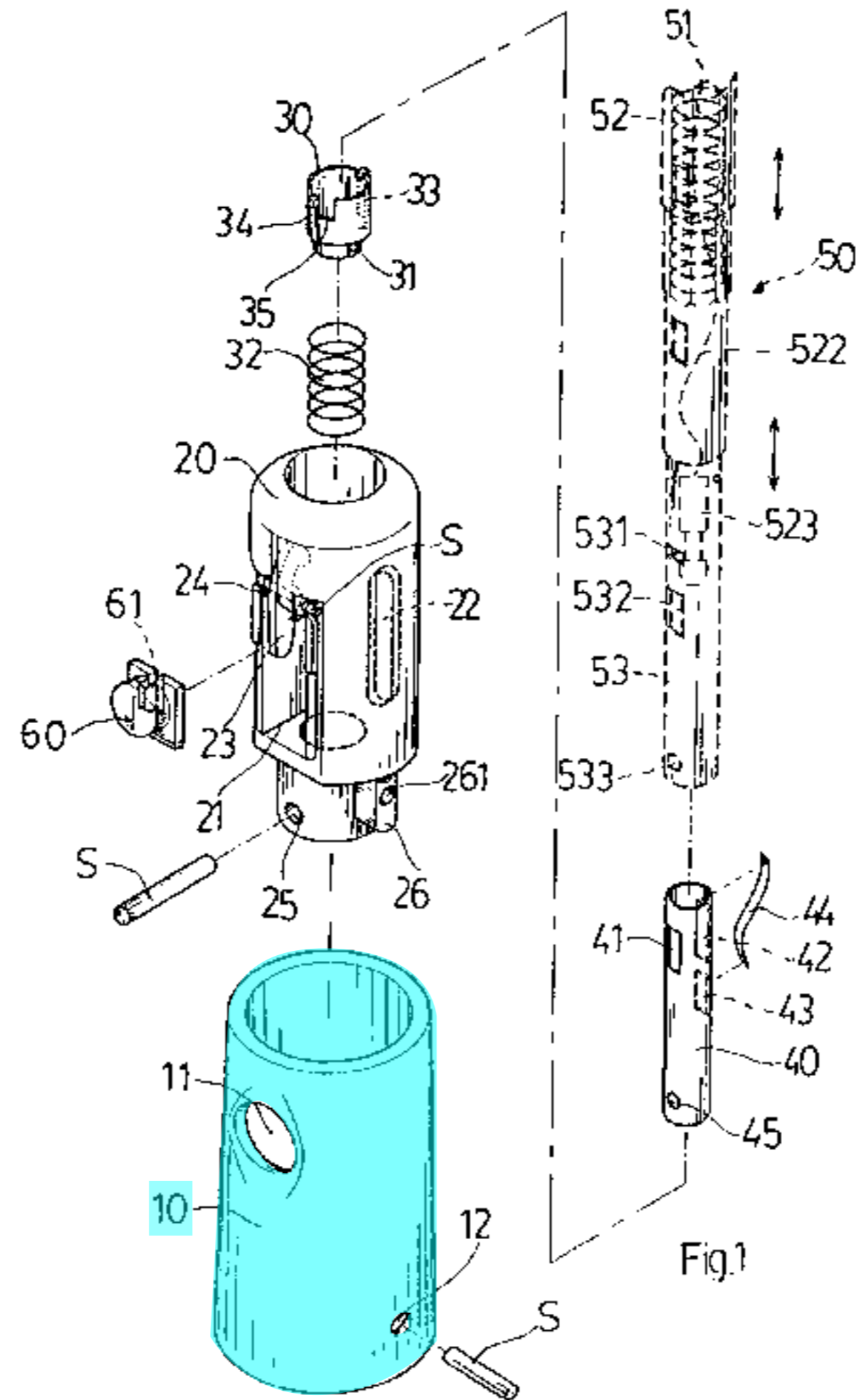

Socket 20

The socket **20** is mounted inside the handle **10**, comprising a receiving chamber **21**, a longitudinal sliding groove **22** inside the receiving chamber **21**, a transverse pivot **S** disposed inside the receiving chamber **21** at the top, a hook **23** turned about the transverse pivot **S**, a torsional spring **24** mounted on the transverse pivot **S** and connected to the hook **23** to force the hook **23** in one direction, a first transverse pin hole **25** at the bottom end thereof, a side block **26** near the bottom end, and a second transverse pin hole **25** through the side block **26**.

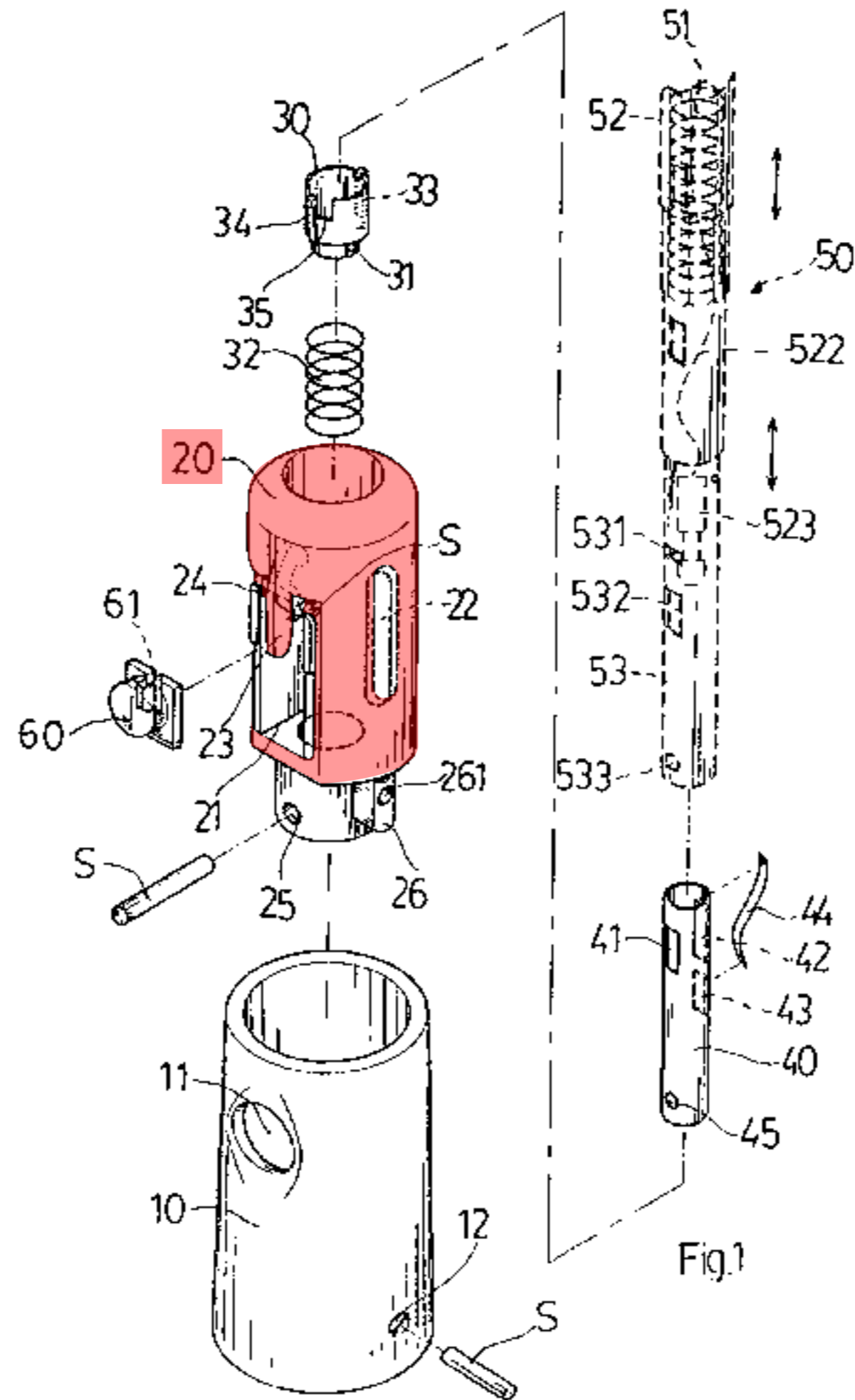

Receptacle 30

The receptacle **30** is supported on a spring **32** inside the socket **20**, comprising a tubular bottom flange **31** coupled to the compression spring **32**, a rib **33** and a pressure strip **34** disposed at two opposite sides, and a rectangular top notch **35** corresponding to the pressure strip **34**.

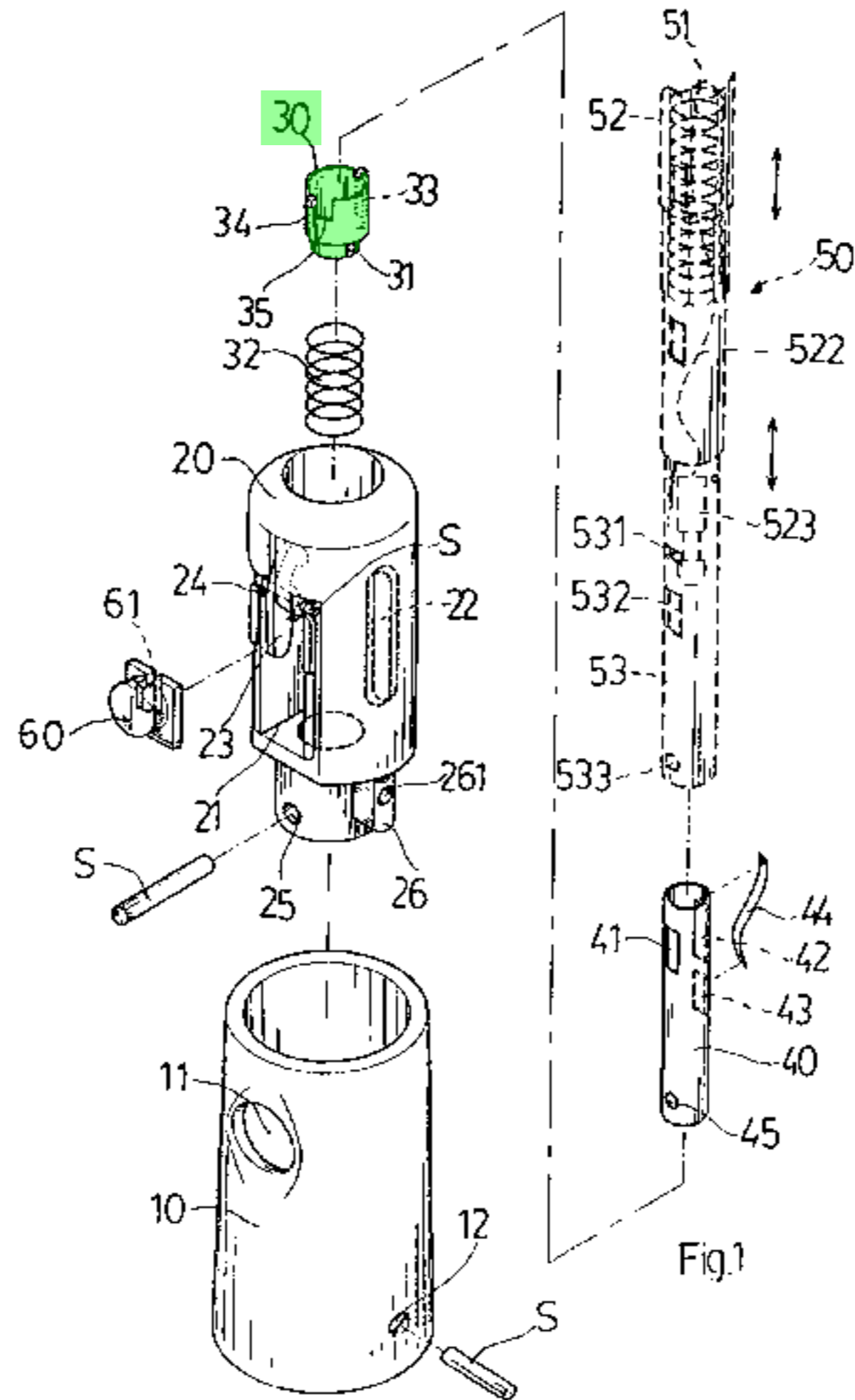

Tube 40

The tube 40 is inserted through the receptacle 30 and the compression spring 32 inside the socket 20, comprising a side hole 41 near the top end thereof, two vertically spaced elongated holes 42 and 43 of different lengths disposed through the peripheral wall at one side opposite to the transverse side hole 41, a pressure spring 44 fastened to the elongated holes 42 and 43, and a transverse pin hole 45 near the bottom end thereof.

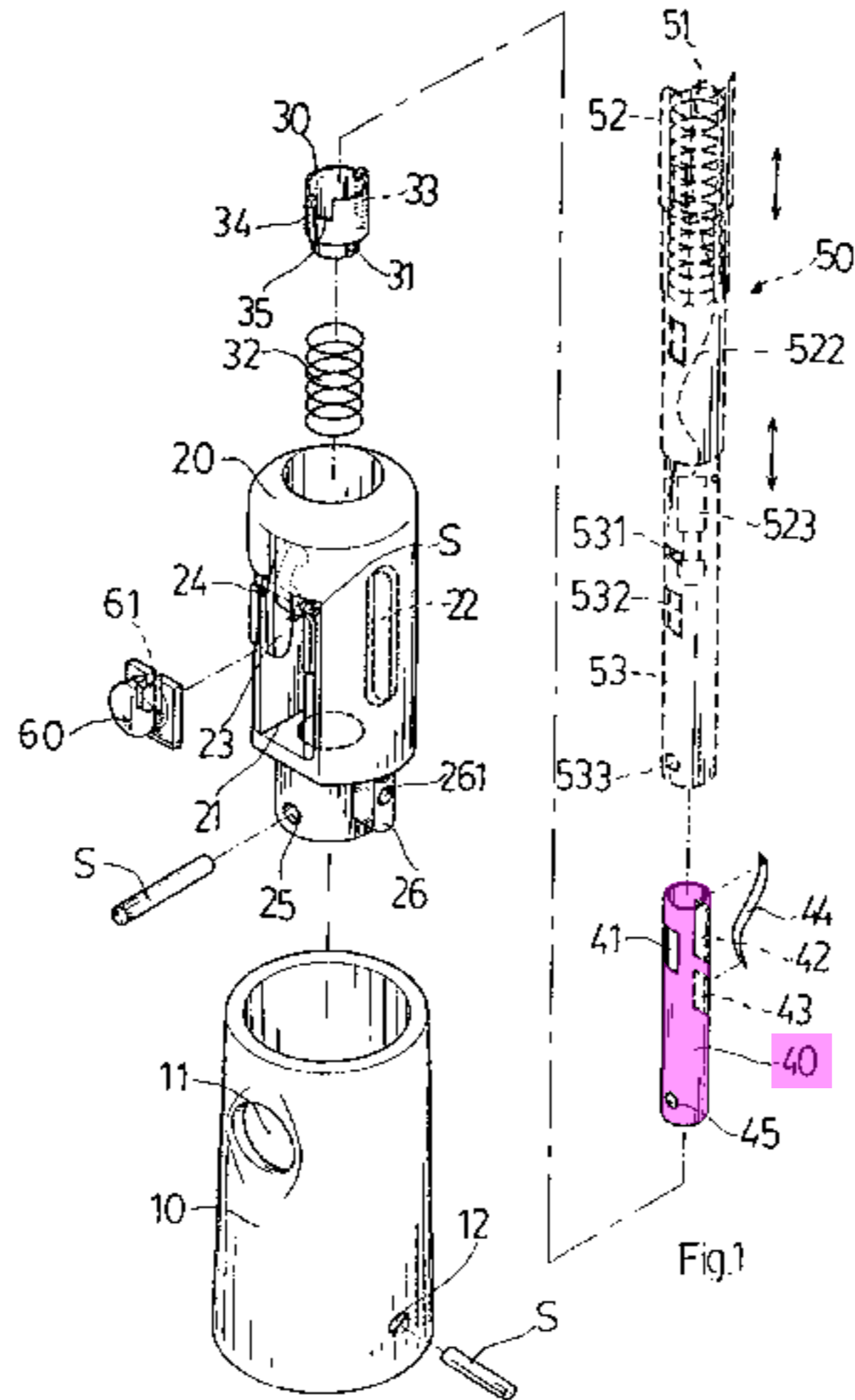

Umbrella shaft 50

The umbrella shaft **50** is inserted into the receptacle **20** and sleeved onto the tube **40** and fastened to the first pin hole **25** at the socket **20**, comprised of an inner metal tube **53**, and outer metal tube **52** sleeved onto the inner metal tube **53**, a return spring **51** mounted inside the outer metal tube **52** and stopped above the inner metal tube **53**, a pulley **521** mounted inside the outer metal tube **52**, a pull cord **522** wound round the pulley **521**, the pull cord **522** having a top end fixedly connected to the top end of the umbrella shaft **50** and a bottom end suspended in the umbrella shaft **50**, and a retainer bit **523** suspended from the bottom end of the pull cord **522**. The inner metal tube **53** comprises a transverse pin hole **533** near the bottom end thereof, a hook hole **531** spaced above the transverse pin hole **533** at one side, and an opening **532** spaced between the hook hole **531** and the transverse pin hole **533**.

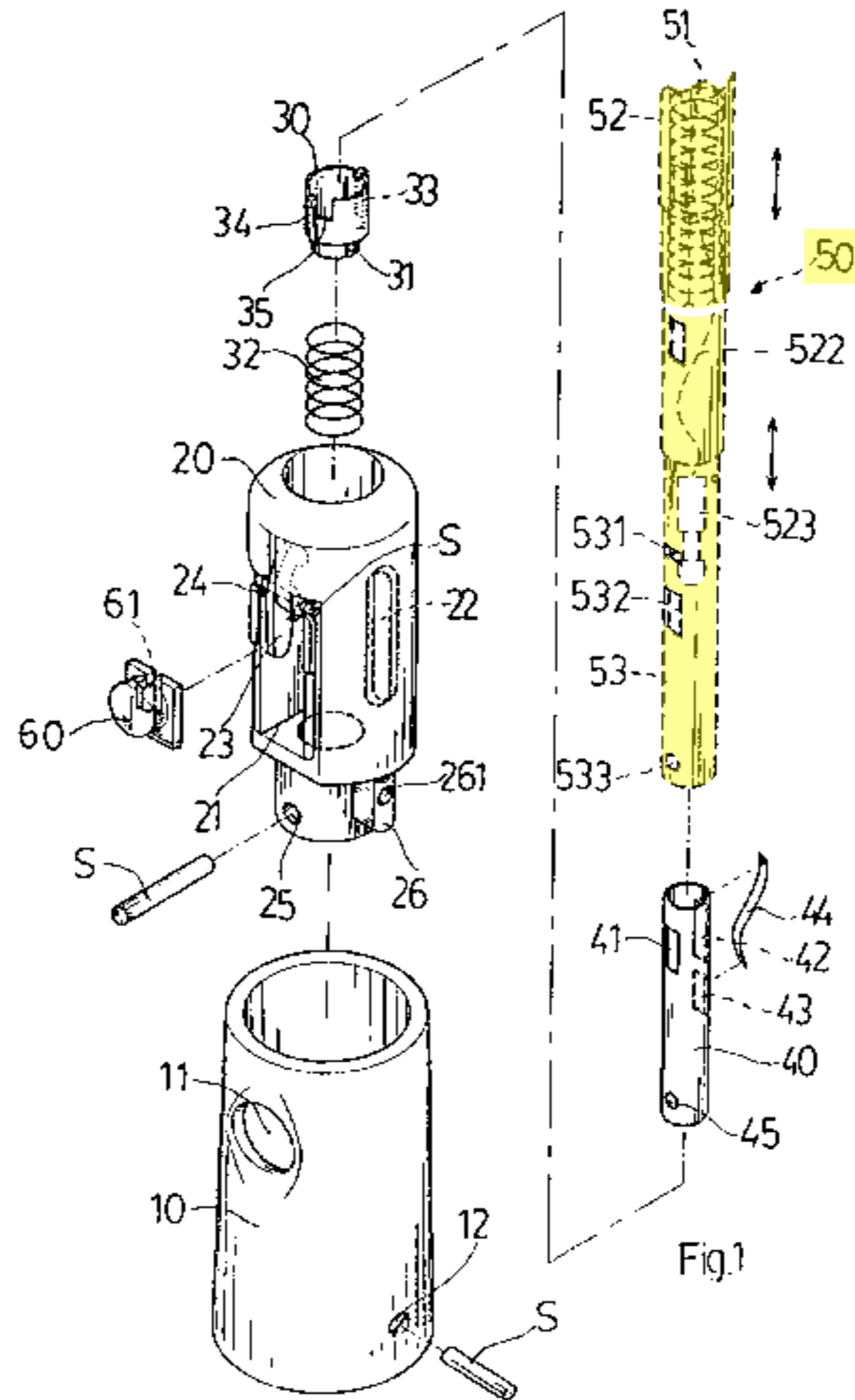

Button 60

The button **60** is mounted in the round hole **11** at the handle **10**, comprising a groove **61** at an inner side corresponding to the hook **23** in the socket **20**.

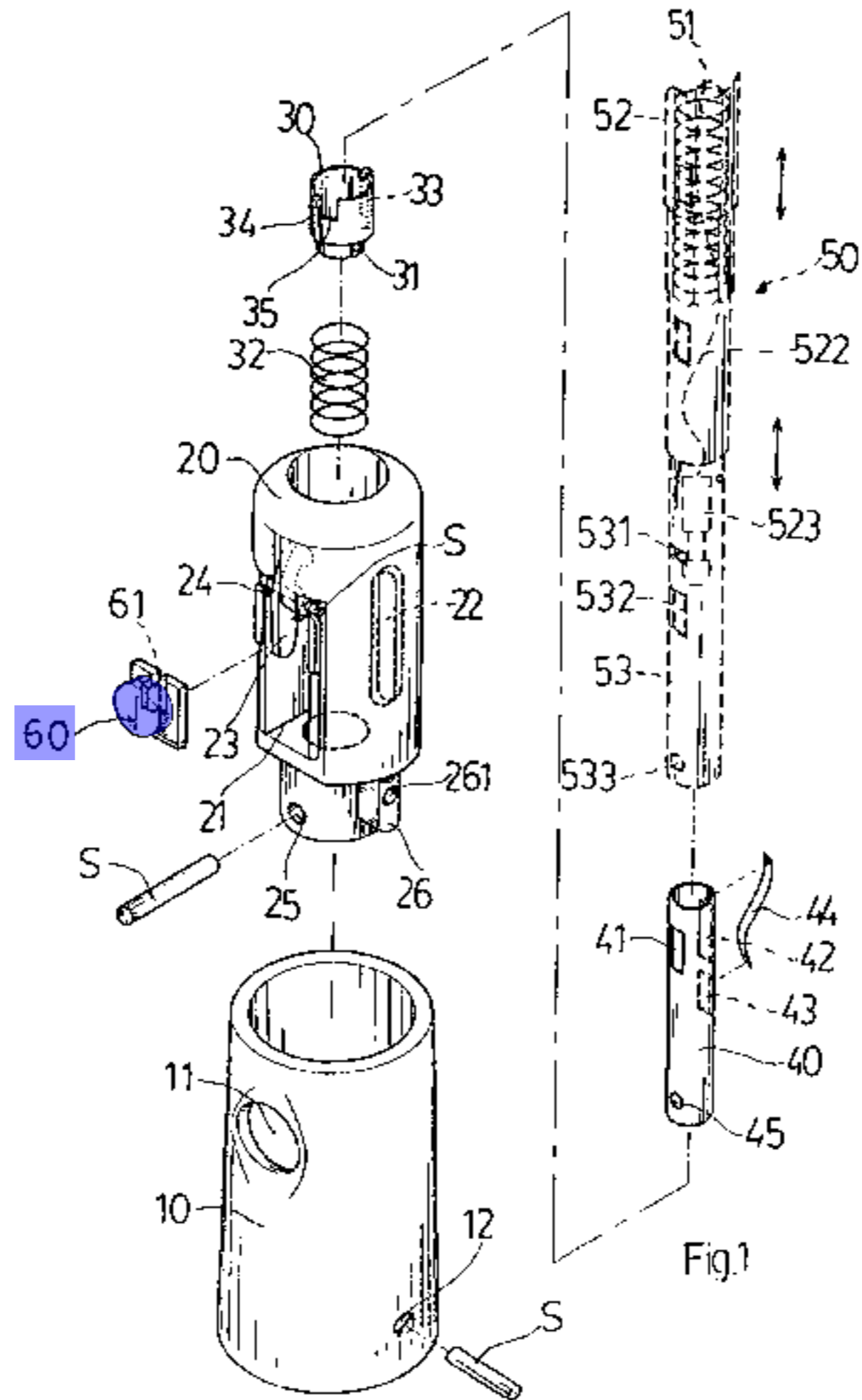

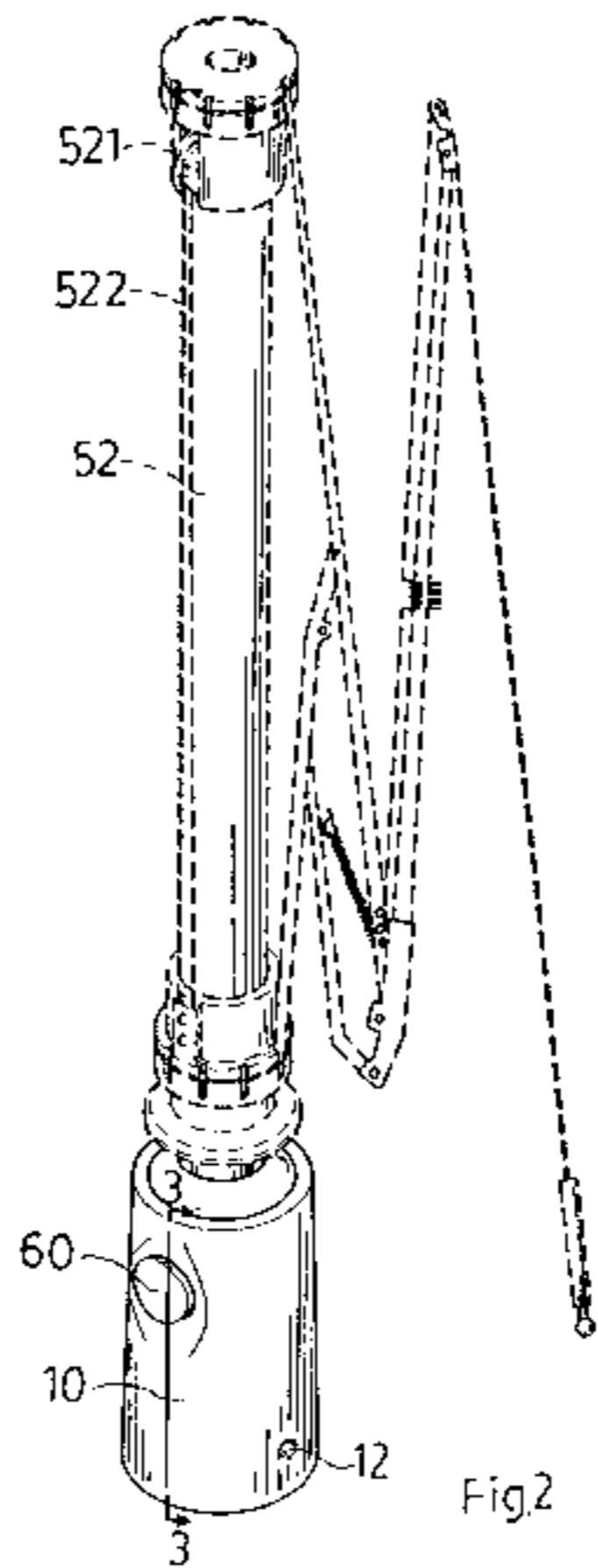

When opening the umbrella, the button **60** is depressed to tilt the hook **23**, causing the hook **23** to be disengaged from the hook hole **531** at the inner metal tube **53**, and therefore the outer metal tube **52** is immediately pushed upwards by the return spring **51** to open the folding collapsible stretcher and rib assembly and the cover on the folding collapsible stretcher and rib assembly (not shown). When the outer metal tube **52** is pushed to the upper limit position, the retainer bit **523** is forced into the side hole **41** at the tube **40** and retained in place by the pressure spring **44**, enabling the umbrella to be maintained in the open position, and at the same time the receptacle **30** is pushed upwards to its former position by the spring **32**, keeping the pressure strip **34** in between the hook **24** in the socket **20** and the retainer bit **523** in the side hole **41** at the tube **40**. When collapsing the umbrella, the button **60** is depressed again to force the hook **23** at the pressure strip **34** against the pressure spring **44**, causing the pressure spring **523** to release the retainer bit **523**, and therefore the umbrella shaft **50** is retracted by the return spring **51**. When collapsed, the umbrella shaft **50** is forced downwards with hand, enabling the hook **23** to hook in the hook hole **513** at the inner metal tube **53** again.

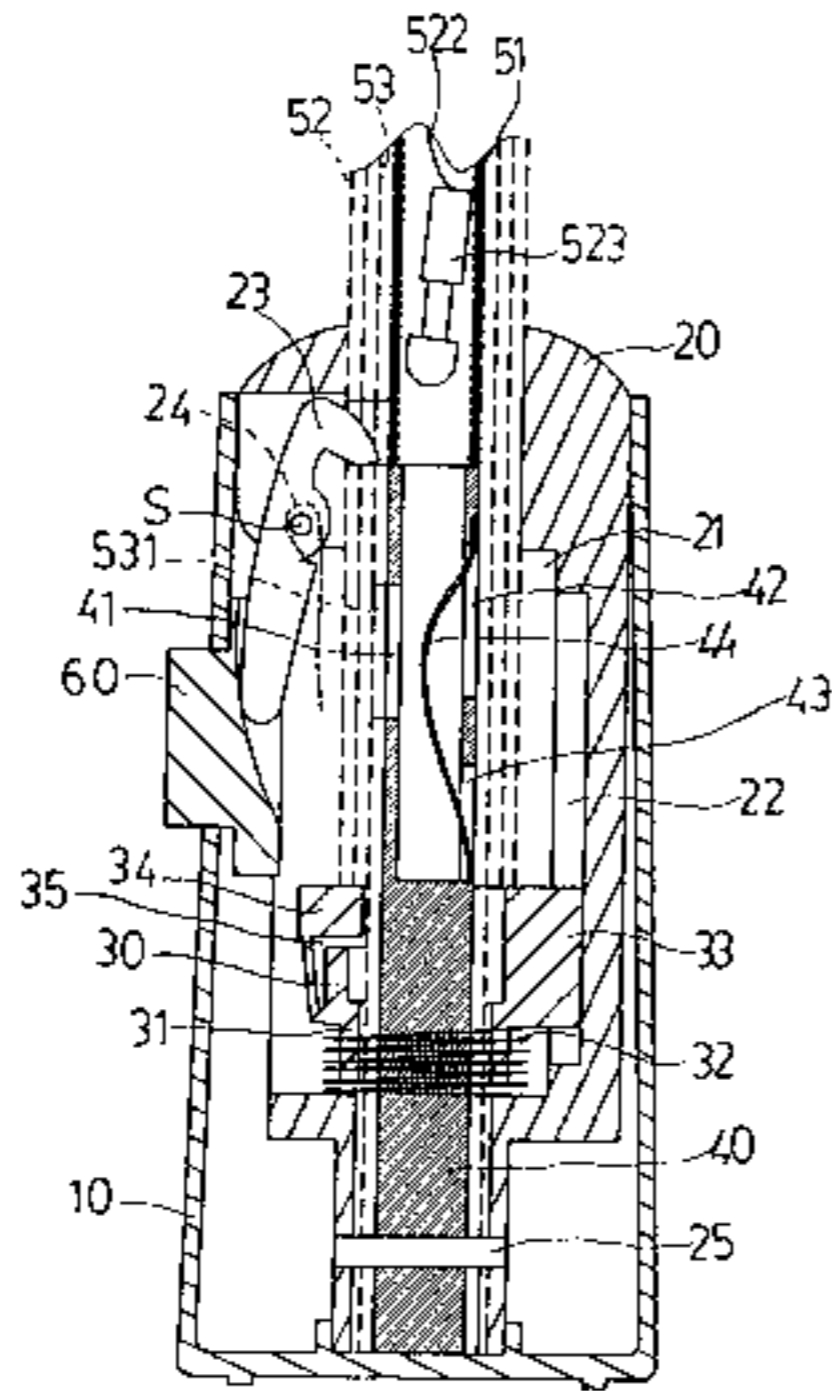

Fig. 3A

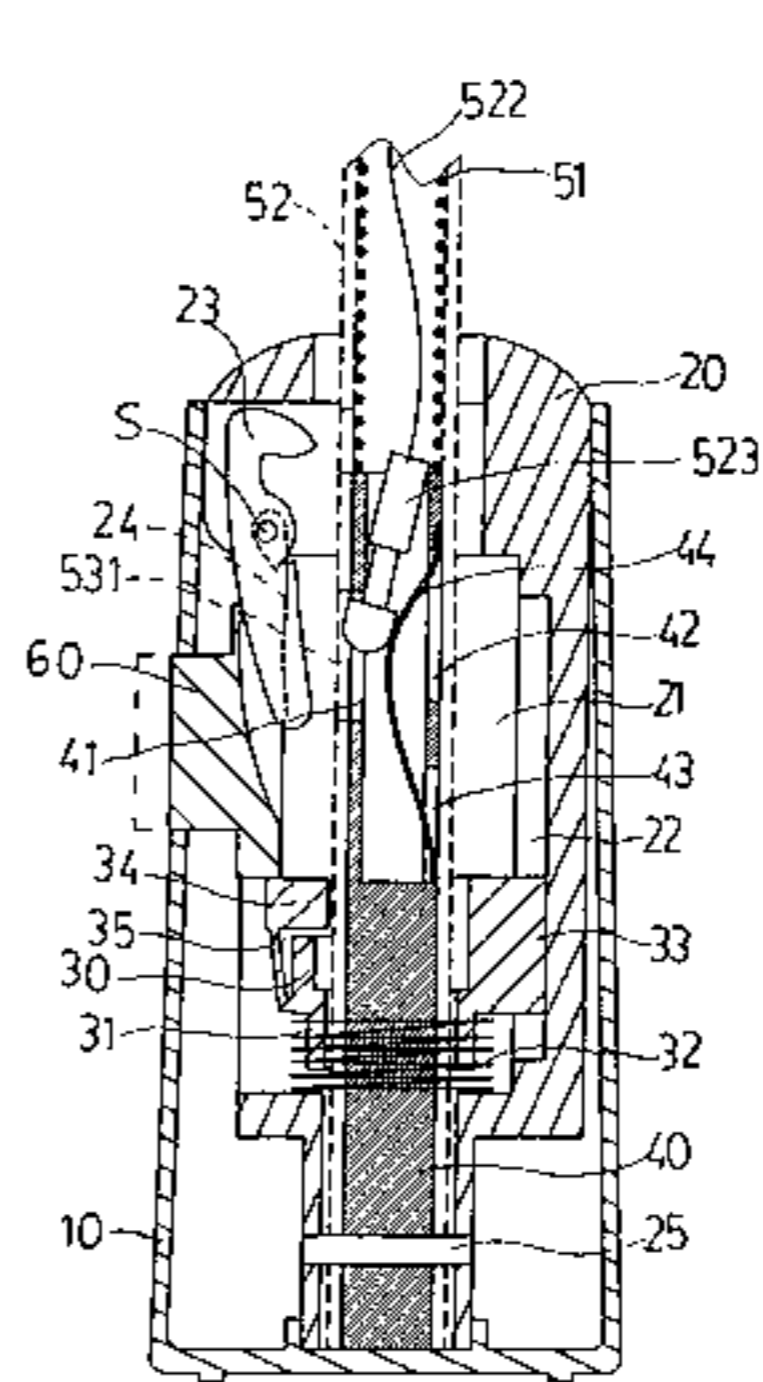

Fig. 3B

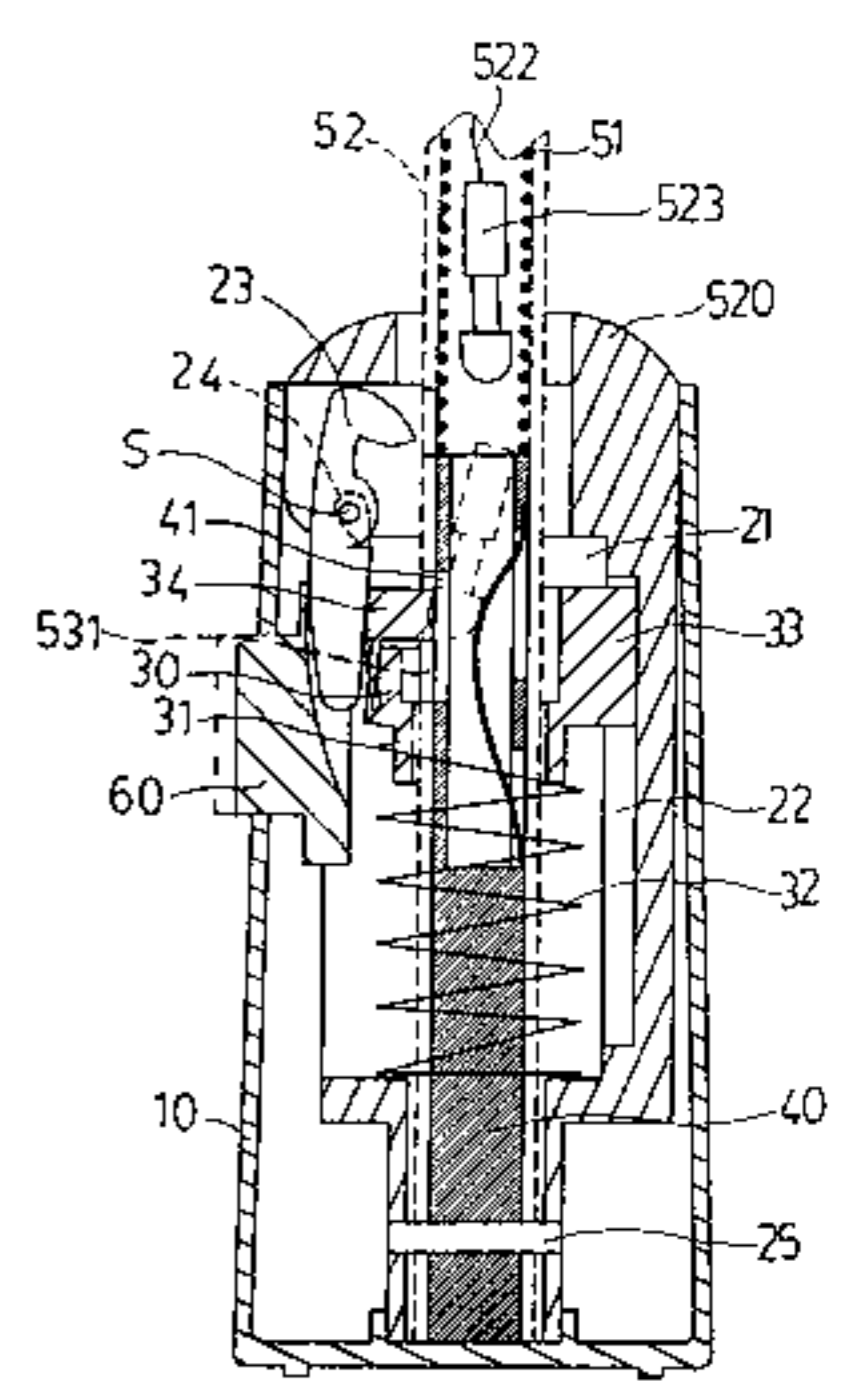

Fig. 3C

Cultural Impact

Bring people together, rain or shine.



Used in a sexual context.



Under our **umbrella**



#DUREXCONDOMEMOJI



Express sympathy or other emotions through art.





Symbolically used to portray safety and coverage.

TRAVELERS  **J**



Used as a fashion accessory.



Voice powerful statements as a whole.



Serve as a great excuse to get closer to someone.



*Here, take my umbrella.
Wouldn't want you to
ruin that gorgeous hair.*

Paired with other objects for different uses.



Provide protection.



They're so important that we designate space for them.



